

GS/L G RA 25S4 1220X685

Galvanised hand pallet truck (2.500 kg)



MR HYDRO

Mr. Hydro series, which is available in numerous versions, is the ideal tool to handle loads in humid and damp conditions. In particular the "inox" version is suitable for environments where high hygienic standards are enforced, such as the chemical, pharmaceutical or food & beverage industry.

GS/G

The galvanised pallet truck offers good resistance to corrosion thanks to the hot dip galvanizing process of the frame and the handle.

ANTI RUST COATING HYDRAULIC PUMP

Resistant and reliable one piece cast iron pump with GEOMET® surface coating treatment to prevent rust pitting and corrosion damages.

Worked with numerical control machine, it includes:

- **MAXIMUM PRESSURE VALVE:** safety device that ensures the transpallet against overloads. When the pressure inside the hydraulic circuit exceeds the calibration value according to the maximum nominal flow, the valve automatically locks the forks.
- **PROPORTIONAL LOWERING VALVE:** lowering speed can be proportionally controlled according to the lever position on the tiller. Perfect working tool to carry fragile and delicate loads like crystal, glass and ceramics.

STANDARD CONFIGURATION

- Nylon steering wheels
- Nylon rollers
- 2 Curves handle with all the controls (lowering / drive position / lifting) available in a single lever for simple and safe control
- Entry/exit rollers. Supplementary rollers allow easier entrance and quicker exit from a closed pallet, reducing the impact on main rollers and guaranteeing longer life



Descriere

1.1 Producător			LIFTER
1.3 Comandă			Manual
1.4 Poziție operare			Pedestru
1.5 Capacitate maximă	Q	Kg	2500
1.6 Distanța la centrul de aplicare al sarcinii	c	mm	610
1.8 Sarcina de la osie la capătul furcilor	x	mm	1002
1.9 Ampatament	y	mm	1262

Greutăți

2.1 Greutate de operare		Kg	71
2.2 Sarcină osie, încărcare pe spate		Kg	1800
2.2 Sarcină osie, încărcare pe față		Kg	771
2.3 Sarcină osie, liber spate		Kg	25
2.3 Sarcină osie, liber față		Kg	46

Cauciucuri/Șasiuri

3.2 Mărime cauciuc: roți direcție - Diametru		mm	200
3.2 Mărime cauciuc: roți direcție - Lățime		mm	50
3.3 Mărime cauciuc: transportoare cu role - Diametru		mm	82
3.3 Mărime cauciuc: transportoare cu role - Lățime		mm	60
3.5 Dimensiune cauciuc: roți spate		nr	4
3.5 Ax de echilibru spate			No
3.6 Ecartament, față	b10	mm	155
3.7 Ecartament, spate	b11	mm	535

Dimensiuni

4.4 Înălțime stivuitor	h3	mm	115
4.9 Înălțime manetă în poziția de deplasare, max	h14	mm	1160
4.15 Înălțime, coborât	h13	mm	85
4.19 Lungime globală	l1	mm	1620
4.20 Distanța până la suprafața frontală a furcilor	l2	mm	400
4.21 Lățime globală	b1	mm	685
4.22 Dimensiuni furcă - grosime	s	mm	55
4.22 Dimensiuni furcă - Lățime	e	mm	150
4.22 Dimensiuni furcă - Lungime	l	mm	1220
4.25 Distanța între furci	b5	mm	685
4.32 Gardă la sol și mijloc ampatament	m2	mm	30
4.34 Lățime culoar	Ast	mm	1855
4.35 Rază de virare	Wa	mm	1437

Performante

5.2 Viteză de ridicare, încărcat	strokes		13
5.2 Viteză de ridicare, descărcat	strokes		13

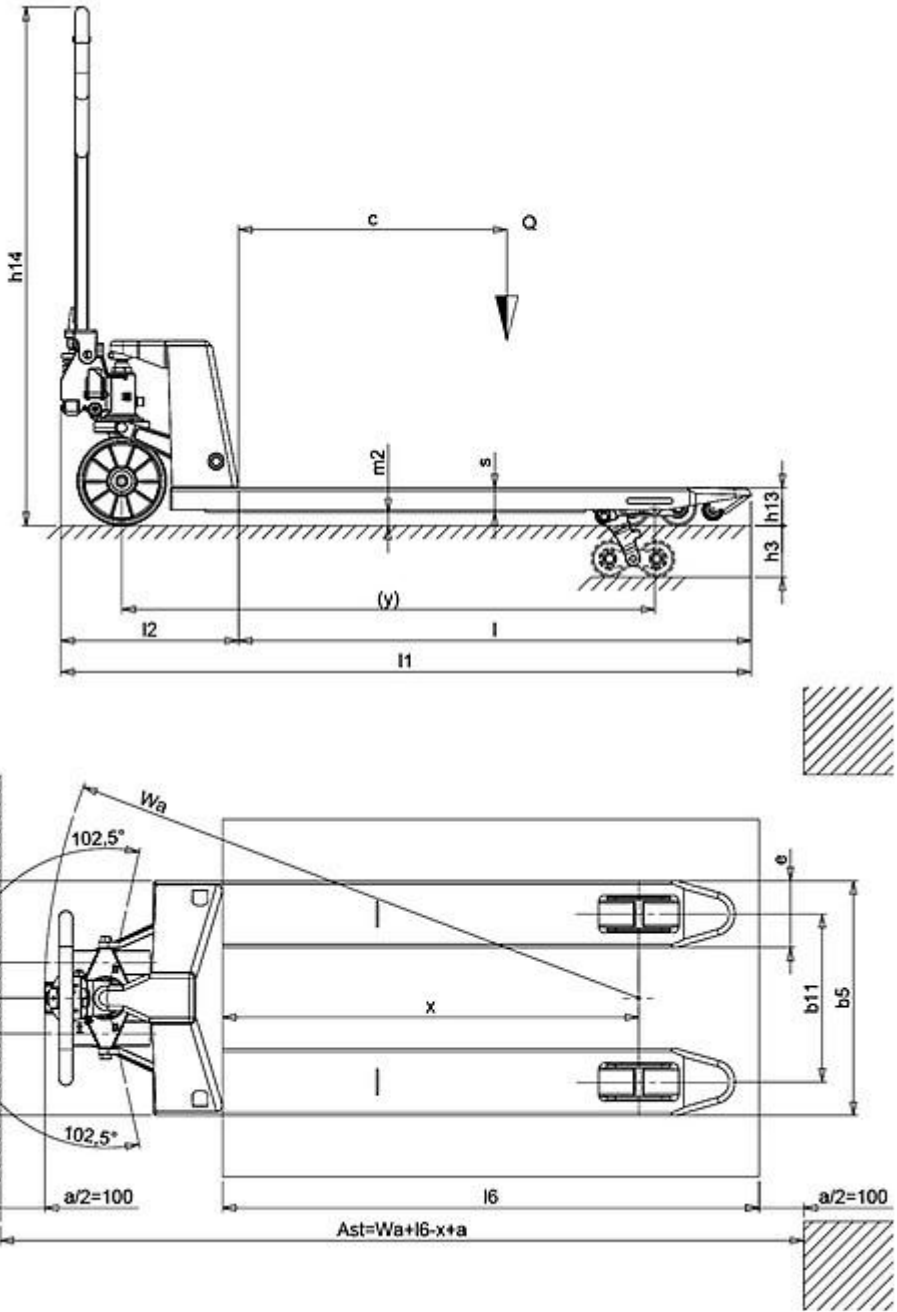

The information is aligned with the Data file at the time of download. Printed on 24/02/2020 (ID 598)

©2019 | PR INDUSTRIAL s.r.l. | All rights reserved | Image shown may not reflect actual package. Specifications subject to change without notice

